



 **EMPIRE STATE**
— BUILDING SUPPLY —

- Affordable Prices
- Trusted Quality
- Reliability

**PRODUCT
CATALOG**

SCAFFOLDING FRAMES & CLAMPS

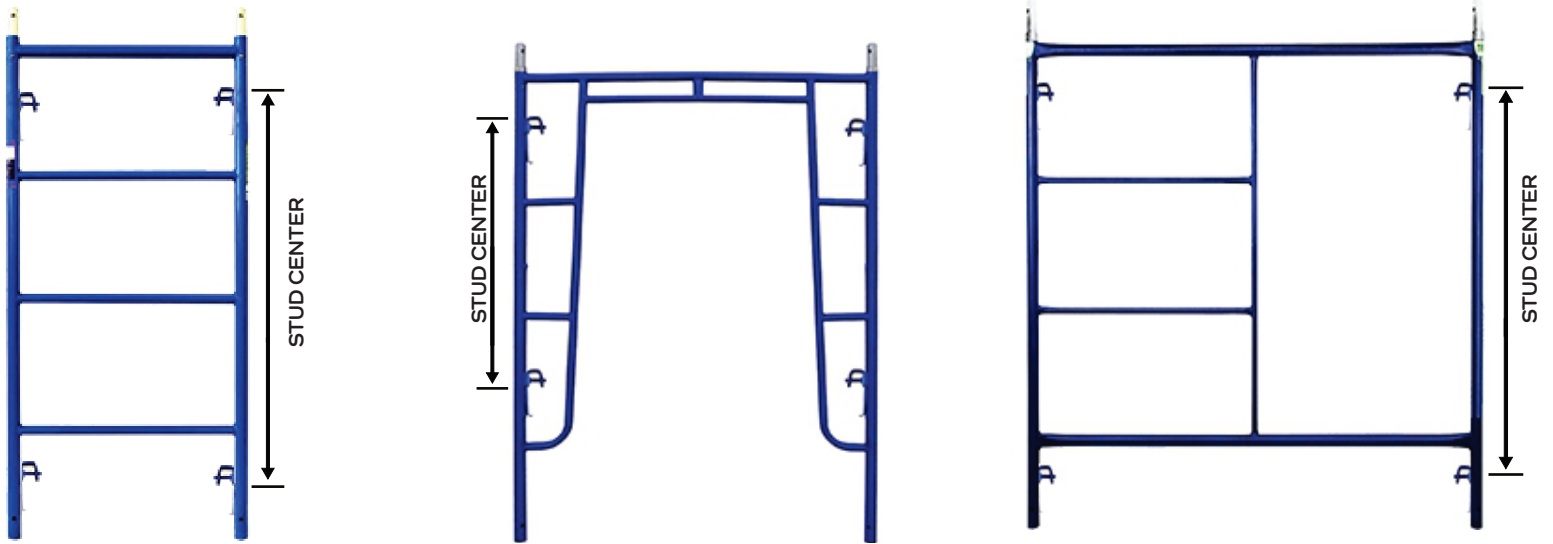

DESCRIPTION	STUD CENTER	WEIGHT
6'4"H X2'W LADDER FRAME	4'	33 LBS
6'4"H X3'W LADDER FRAME	4'	40 LBS
6'4"H X3'W WALK THROUGH FRAME	4'	40 LBS
6'4"H X42"W WALK THROUGH FRAME	4'	43 LBS
6'4"H X5'W WALK THROUGH FRAME	4'	48 LBS
2H X5'W MASONRY FRAME	1'	24 LBS
3H X5'W MASONRY FRAME	2'	27 LBS
4'H X5'W MASONRY FRAME	3'	34 LBS
5'H X5'W MASONRY FRAME	4'	37 LBS
6'4"H X5'W MASONRY FRAME	4'	43 LBS



2" STUD CLAMP

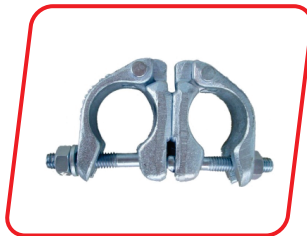

2"X2" SWIVEL CLAMP

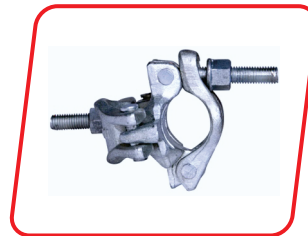

2"X2" RIGHT ANGLE

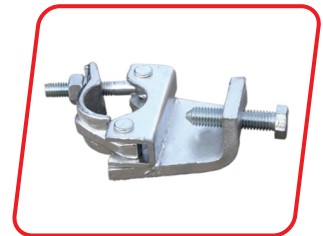

2" BEAM CLAMP

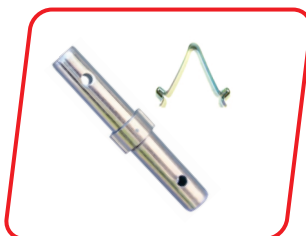

COUPLING PIN



GRAVITY PIN / TOGGLE PIN



8" CASTER WHEEL

CROSS BRACES & PLANKS

A	B	C
4'	4'	5'6.910"
5'	4'	6'4.810"
6'	4'	7'11.20"
7'	2'	7'2.37"
7'	3'	7'3.37"
7'	4'	8'.075"
8'	1'	8'1.62"
8'	2'	8'2.93"
8'	3'	8'6.5"
8'	4'	8'11.31"
10'	4'	10'9.25"

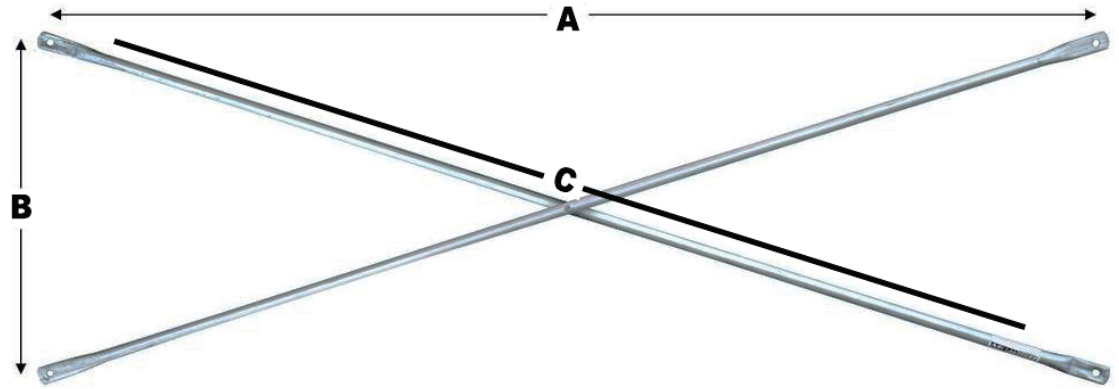

DESCRIPTION
OSHA PLANK 2" X 10" X 10'
OSHA PLANK 2" X 10" X 12'
ALUMINUM PLANK 4' X 19"
ALUMINUM PLANK 5' X 19"
ALUMINUM PLANK 6' X 19"
ALUMINUM PLANK 7' X 19"
ALUMINUM PLANK 8' X 19"



24" SCREW JACK



24" SOCKET S/J



3', 4', 6' WALL TIE



GUARDRAIL POST



FIX BASE PLATE



SWIVEL BASE PLATE

BRACKETS & LADDERS

DESCRIPTION	WEIGHT
12" SIDE BRACKET	6 LBS
20" SIDE BRACKET	9 LBS
30" SIDE BRACKET	14 LBS
40" SIDE BRACKET	19 LBS
50" SIDE BRACKET	24 LBS
60" SIDE BRACKET	30 LBS
20" END BRACKET	9 LBS
30" END BRACKET	14 LBS

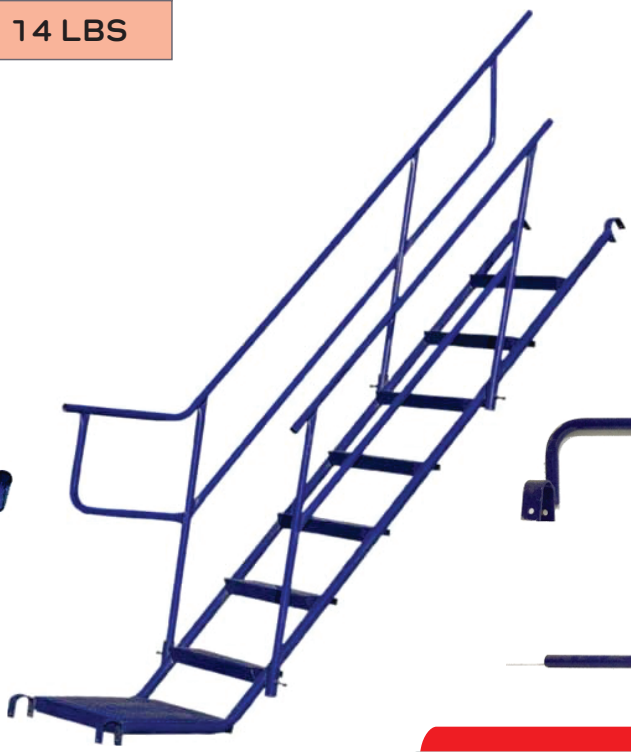
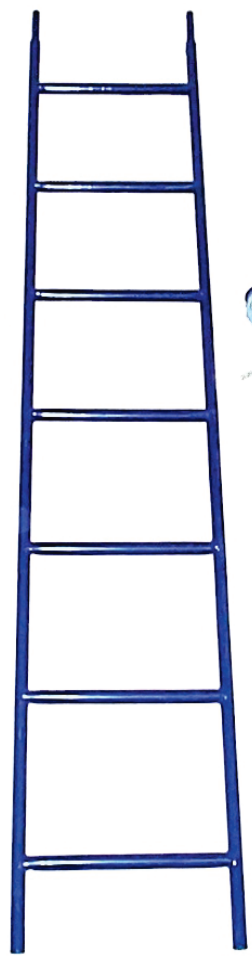
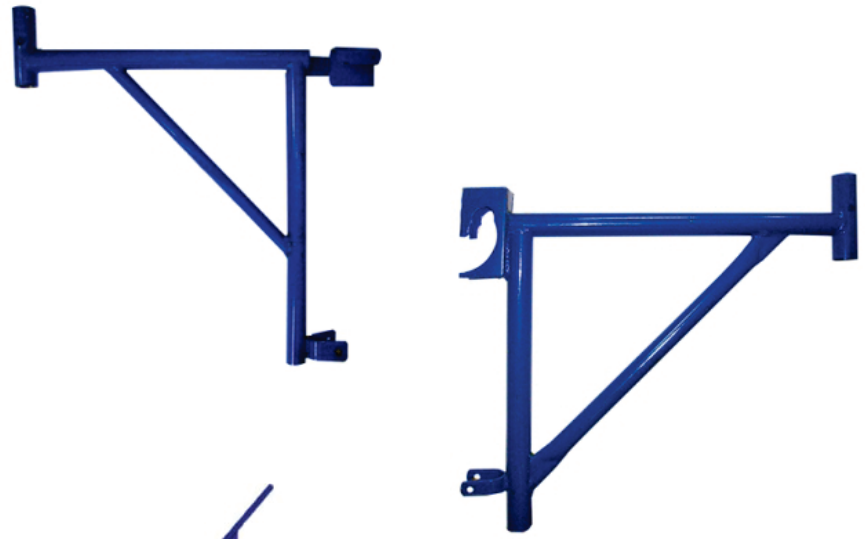

DESCRIPTION	WEIGHT
7' STAIRWAY UNIT	125 LBS
8' STAIRWAY UNIT	136 LBS
8' END GUARD	25 LBS
5' END GUARD	12 LBS



PUMP JACK & BAKER SCAFFOLD



PUMP JACK



WORK BENCH



POLE CONNECTOR 6



PLATFORM



BAKER SCAFFOLD



SAFETY GUARDRAIL



OUT RIGGER



DEEP TRUSS 16, 18, 20, 22, 24



PUTLOG 10, 12, 14



PUTLOG HANGER



SADDLE PIN



PARALLEL HANGER



RIGHT ANGLE HANGER



3"X2" RIGHT ANGLE CLAMP



3"X2" SWIVEL CLAMP



3"STUD CLAMP

CLOSE HEIGHT	OPEN HEIGHT	SAFE LOAD	WEIGHT
36	60	6500-7800 LBS	24 LBS
56	80	6300-7800 LBS	32 LBS
66	110	5600-6700 LBS	41 LBS
86	130	6700-7900 LBS	57 LBS
106	160	5700-6200 LBS	68 LBS

SHORING FRAMES & ACCESSORIES

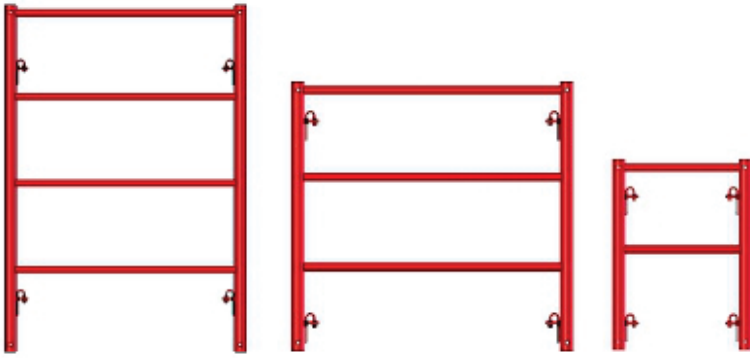

DESCRIPTION	STUD CENTRE	WEIGHT
6'H X 4'W	4'	64 LBS
5'H X 4'W	4'	53 LBS
4'H X 4'W	4'	47 LBS
3'H X 4'W	4'	45 LBS
6'H X 2'W	4'	55 LBS
5'H X 2'W	4'	43 LBS

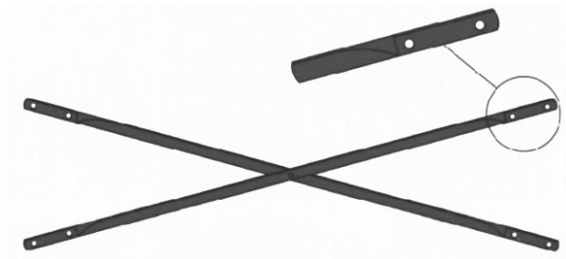

DESCRIPTION	WEIGHT
DOUBLE HOLE ANGLE CROSS BAR 4 X 3 X 4	9.70 LBS
DOUBLE HOLE ANGLE CROSS BAR 5 X 3 X 4	11.24 LBS
DOUBLE HOLE ANGLE CROSS BAR 6 X 3 X 4	6.0 LBS
DOUBLE HOLE ANGLE CROSS BAR 7 X 3 X 4	6.5 LBS
DOUBLE HOLE ANGLE CROSS BAR 8 X 3 X 4	7.2 LBS



4X8 U HEAD

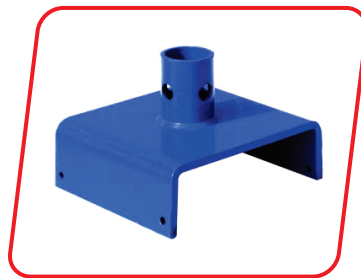

8X8 U HEAD

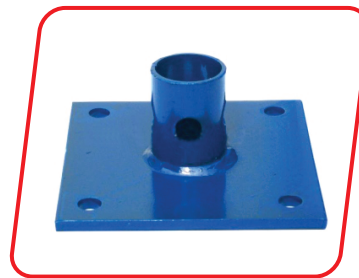

8X8 BASE PLATE



SHORING RIVET & R PIN



SHORING COUPLE PIN



SHORING SOCKET
SCREW JACK



SHORING SCREW
JACK WITH PLATE



SHORING SCREW
JACK WITH 8X8 U HEAD



REGULAR SCREW JACK
WITH 8X8 U HEAD



2-1/2X2 RIGHT
ANGLE CLAMP



2-1/2X2
SWIVEL CLAMP



2-1/2" STUD CLAMP

MODULAR PLATFORM



ROLLER BUMPER



CONNECTING FRAME



END STIRRUP

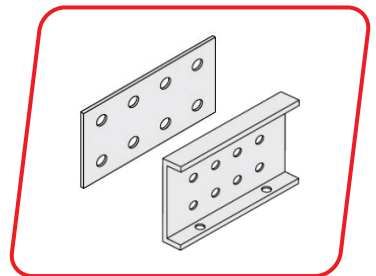

SPLICE PLATES

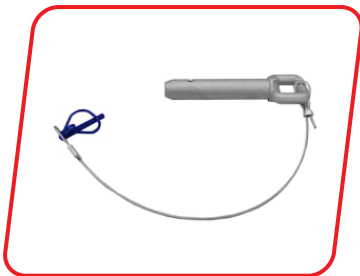

LOCK PIN



10/3 POWER CORD



STEP DOWN & STEP UP TRANSFORMER



10/3 50' YOKE WITH MOLDED END



PARAPET WALL CLAMP



WIRE ROPE



FIXED CORNER



COUNTER WEIGHT

ALUMINUM PLATFORM & ACCESSORIES

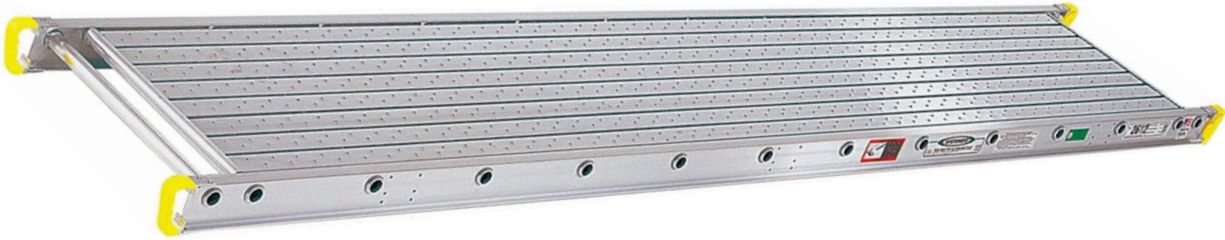

DESCRIPTION	LOAD
28X8 TO 20 TWO MAN ALUMINUM PLATFORM	500 LBS
28X22 TO 40 THREE MAN ALUMINUM PLATFORM	700 LBS

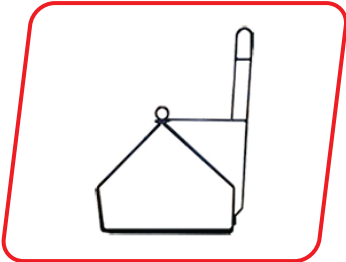

STIRRUP D



C HOOK



SAFETY ROPE / LIFELINE

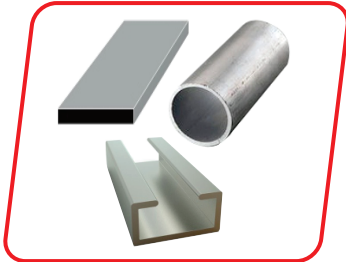

ALUMINUM FLAT TOE BAR RAILING & C TYPE TOE BAR



FIRST GRIP THIMBLE



5/16 WIRE ROPE



STANDARD END STIRRUP



16, 18, 20, 22, 24, 30 FLAME CUT C HOOK



TURN BUCKLE



MODULAR END GATE



5/8 & 3/4 SHACKLE



WALL ROLLER BUMPER

SIDE WALK BRIDGE MATERIAL



ALL SIZE SIDE WALK BRIDGE POLE

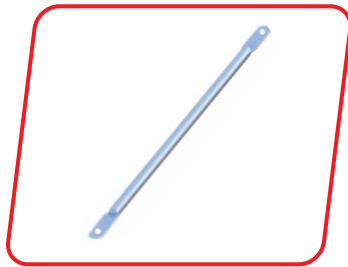

ALL SIZE GIRTH & BRACE



ALL SIZE HEADER BEAM

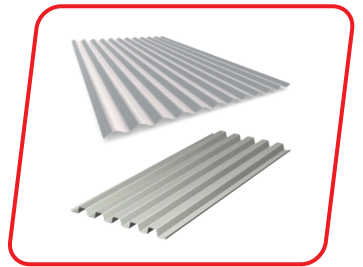

CORRUGATED SHEET & DECKING

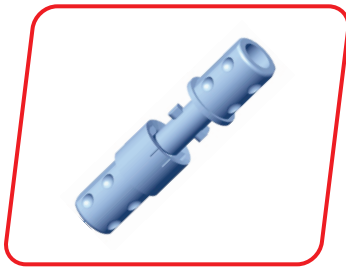

10, 13, 16 CONNECTING TUBE



NUT BOLT

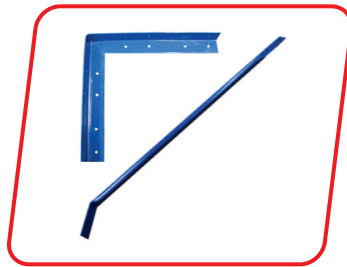

NAILER & PANEL BRACE

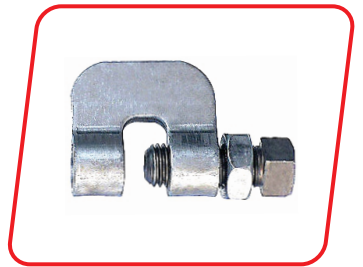

3/4 & 3/8 C CLAMP

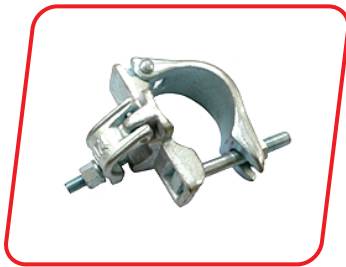

3-1/2X2 RIGHT ANGLE CLAMP



3-1/2 STUD CLAMP

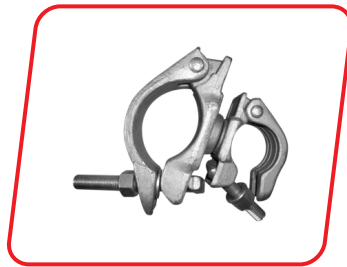

3-1/2X2 SWIVEL CLAMP

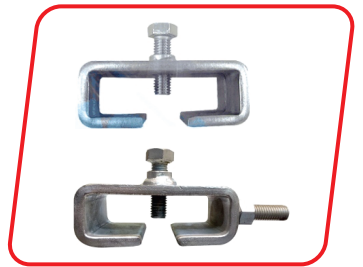

HEADER CLAMP
HEADER CLAMP WITH STUD

SIDE WALK SHED EQUIPMENT



19 & 16 GAUGE WIRE MESH



8,10,12 WOOD PLANK



16D & 20D DUPLEX NAIL
50 LBS BOX



#9 WIRE



3/4" & 1/2"
ALUMINUM PIPE



#12, #14 ALL COLORS
STANDARD & SOLID WIRES



1/2 & 3/4 LIGHT FIXTURE
LED BULB



GROUNDING ROD
& CLAMP



STRING LIGHTS



EXTENSION CORD



COUPLING CONNECTOR
& STRAP

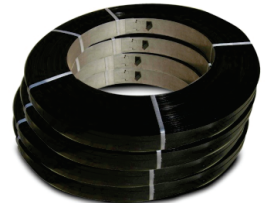

3/4" STEEL STRAP



WINCH STRAP



WINCH & WINCH BAR

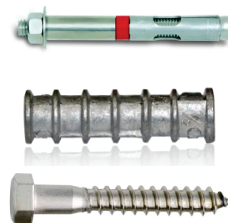

ALL SIZE ANCHOR BOLTS



STEEL STRAP
DISPENSER

ACCESSORIES



8'6"X100'
FIRE RETARDANT
SCAFFOLD SHEET



8'6"X150'
FIRE RETARDANT
DEBRIS NETTING



4' X 150'
FIRE RETARDANT
ORANGE NETTING

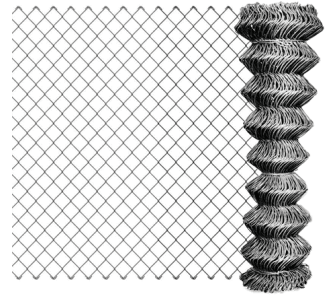

8' X 50'
CHAIN LINK FENCE
9G & 11G



WIRE MESH BASKET



OPEN RACK PALLET



WATER BARRIER

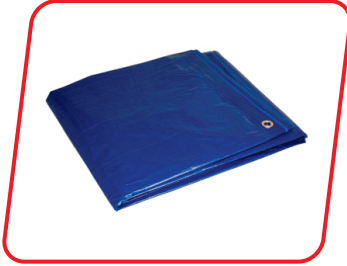

BLUE TARP



CLEAR PLASTIC



RATCHET HANDLE
& SOCKET



WORK LIGHT



GFCI



WHEEL BARROW

MATERIAL HOIST



BETAMAX HOIST



SUSPENSION BRACKET



MATERIAL BASKET



MORTAR TUB



WEIGHT BRACKET



BRICK BASKET



SWIVEL BRACKET



PULLEY & BRACKET



CHAIN HOIST

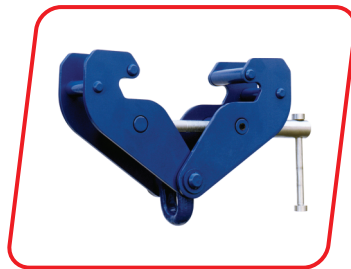

BEAM CLAMP



BEAM TROLLEY



12" PULLEY



PRESSURE WASHER



HAMMER DRILL



5" TUCK POINT GRINDER



JACK HAMMER



CEMENT MIXER



GENERATOR



VACUUM



CIRCULAR SAW



AC 100 EPOXY



TUCK POINT BLADE

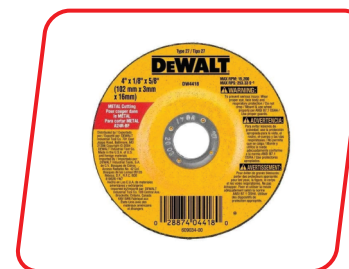

METAL CUTTING BLADE



CIRCULAR SAW BLADE



ALL SIZE DRILL BITS



CHISEL



ALL COLORS
SIKA 15LM & 1A



HUNTER GREEN &
SILVER PAINT

ACCESSORIES



SAFETY LOCK & HOOK



SAFETY HARNESS LANYARD



HARD HAT



RED & BLUE PALM GLOVES



SAFETY VEST



**DUST MASK
SAFETY GLASSES**



CANVAS BUCKET



SAFETY CONE



SAFETY FLAG



CAUTION TAPE



SAND BAG



STUCCO MATERIAL



YARD BUSH BROOM



PRESSURE WASHER HOSE



HAND TRUCK



CONCRETE WIRE MESH



BOSCH

STANLEY



EMPIRE STATE BUILDING SUPPLY

51 W HILLS RD, HUNTINGTON STATION, NY 11746,

Ph. +1 631-201-7000, +1 631-201-7777

Email: empirestatebuildingsupply@gmail.com

www.empirestatebuildingsupply.com